

SAVE THESE IMPORTANT SAFETY INSTRUCTIONS



This manual contains important safety, operating, and installation instructions – read before using charger.

Battery Safety Information

Warning: Use charger only on battery systems with an algorithm selected that is appropriate to the specific battery type. Other usage may cause personal injury and damage. Lead acid batteries may generate explosive hydrogen gas during normal operation. Keep sparks, flames, and smoking materials away from batteries. Provide adequate ventilation during charging. Never charge a frozen battery. Study all battery manufacturers' specific precautions such as recommended rates of charge and removing or not removing cell caps while charging.

Electrical Safety Information

Danger: Risk of electric shock. Connect charger power cord to an outlet that has been properly installed and grounded in accordance with all local codes and ordinances. A grounded outlet is required to reduce risk of electric shock – do not use ground adapters or modify plug. Do not touch uninsulated portion of output connector or uninsulated battery terminal. Disconnect the AC supply before making or breaking the connections to the battery while charging. Do not open or disassemble charger. Do not operate charger if the AC supply cord is damaged or if the charger has received a sharp blow, been dropped, or otherwise damaged in any way – refer all repair work to qualified personnel. Not for use by children.

Function

- Intelligent MCU control charging
- Short circuit protection
- Over temperature protection
- Loose battery connection alarm
- Over-voltage protection
- Battery reverse connection protection

Description

HP series charger is a highly durable on- or off-board charging solution. The charger can store several charge profiles for specific types of lead acid and lithium motive battery packs, to assist customers in achieving battery charging flexibility. It can automatically realize multi-stage charging: constant current, constant voltage, etc. It has multiple protection functions. Applications include aerial work platforms, floor care machines, lift trucks, motorcycles, scooters, and utility vehicles.

IMPORTANT NOTICE: This manual contains important safety and operating instructions for the charger. Read the entire manual before using charger.

User's Guide for HP Series Intelligent Charger

- Timing shutdown protection
- Charging status LED display
- Record Historical Charging Data

Product Features

- Enclosed Structure - Waterproof, high protection level
- Natural Convection Cooling without Fan - No noise, high reliability
- Internal Silica Gel Filling - Shockproof and Anti-impact
- Portable and On-board Design - Easy to use

Operating Instructions

- 1) Confirm whether the input voltage meets the requirements before use;
- 2) Check battery polarity. Before charging, make sure whether the battery is connected in the correct way;
- 3) Connect battery, and then connect AC power. The LED of the charger lights up and starts flashing red, yellow and green in turn. Charger starts to work.
- 4) When the charger is working, make sure there is enough space around it to dissipate heat;

User's Guide for HP Series Intelligent Charger

LED Indications

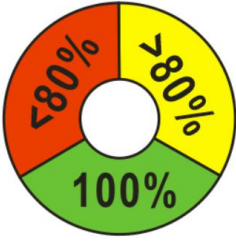

RED	Solid: Being charging. Please wait patiently
	Flashing: Charger error. Refer to troubleshooting instructions below.
YELLOW	Solid: Charging and 80% charging completed.
	Flashing: Display charge profiles, if no battery is connected when power on. Refer to programming instructions.
GREEN	Solid: Charging complete

Troubleshooting Instructions





If a fault occurs, count the number of **red** flashes between pauses and refer to the table 1.

Table 1 Troubleshooting Instructions

Red Flashes	Cause	Solution
	Input voltage is low or unstable.	Check AC input connection including plugs and wires. Check AC input voltage. The operating input voltage range is 100-240vac. This fault will clear automatically once the condition has been corrected.
	Battery not connected. Battery reverse polarity. Battery over discharge. Battery error.	<ul style="list-style-type: none"> • Unreliable connection between charger and Battery. Check the charging plug and socket. • Battery reverse polarity. Check the polarity of the charging plug and socket terminal. • Battery low voltage. Check battery with multimeter. If the 48V battery voltage is lower than 18V, the charger does not work. Charge the battery above 20V by other methods, and then charge with this charger. • Battery error. Battery voltage mismatch or battery damage. Check battery with multimeter. <p>This fault will clear automatically once the condition has been corrected.</p>

IMPORTANT NOTICE: This manual contains important safety and operating instructions for the charger. Read the entire manual before using charger.

User's Guide for HP Series Intelligent Charger

	Standby Mode (Stop Charging)	Charger is in standby mode. Restart charging with mobile phone App or reset charger (interrupt AC power for 15 seconds).
	Over-Temperature	Ensure sufficient cooling airflow. This fault will clear automatically once the condition has been corrected.
	Battery High Voltage	Check battery voltage and condition and reset charger
	Charger Internal Fault	Check AC input connection including plugs and wires. Check AC input voltage. Return to qualified service depot if fault persists
	Short Circuit	Check battery for shorted or damaged cells. Check charger output for shorted. This fault will clear automatically once the condition has been corrected.

Installation Instructions



WARNING: The output of chargers with greater than 48V may pose an energy and/or shock hazard under normal use.

- 1) Use or mount the charger with adequate ventilation. Avoid charger overheating protection
- 2) Use or install such that risk of human contact with hot surfaces is reduced.
- 3) Keep the charger free of oil, dirt, mud, or dust to keep the cooling fins operating as efficiently as possible.
- 4) Pay attention to the heating of the charger casing during the operation.
- 5) Don't put charger on the carpet or cushion, and keep away from flammable and explosive objects, during working.

Function Instructions

- 1) The Interlock is connected and short circuited when the charger is not plugged into AC.

IMPORTANT NOTICE: This manual contains important safety and operating instructions for the charger. Read the entire manual before using charger.

User's Guide for HP Series Intelligent Charger

- 2) After charging completed, the charger automatically starts to recharge if the battery voltage drops below 46V.
- 3) When the charger has been plugged into AC for more than 7 days, the charger automatically starts to recharge if the battery voltage is lower than 48V.

Specifications

DC output	
Mode	HP4820P / HP4820PB *
DC output power - maximum	1100W
DC output current - maximum	20A
DC output voltage - maximum	64.8VDC
Interlock Current - maximum	1A
Minimum Battery Voltage (Allowed to charge)	18VDC
Battery Type	Specific to selected algorithm
Auto-Resume Charging Voltage	46VDC
Auto-Replenish Energy	Less than 48V after 7 days
Default Charge Profile	Trojan flooded
Reverse Polarity	Protection with auto-reset
Short Circuit	Shut down with auto-reset
AC Interlock	Contact is on without AC
*HP4817PB can be connected to mobile phone via bluetooth	

AC Input	
AC Input Voltage - range	85-264VAC
AC Input Voltage-nominal	100-240VAC
AC Input Frequency	45-65Hz
AC Input Current-maximum	12A
Power Factor	>0.95
Mechanical	
Dimensions	278 X 247 X 104 mm
Weight	5kg
Casing material	Aluminium alloy
AC Input Connector	14 AWG wire
DC Output Connector	12AWG wire
Environmental	
Enclosure	IP66
Operating Temp.	-10°C to +45°C
Storage Temp.	-40°C to +70°C

Programming Instructions

The charge algorithm can be changed through the data interface or APP. 4 charge algorithms can be selected. When the charger is powered on and the battery is not connected, the LED displays the current charge algorithm in the charger. Count the number of LED flashes between pauses and refer to the table 2.

Table 2

SN	Battery Type	LED Flashes
1	Trojan Battery flooded(Algld1)	

IMPORTANT NOTICE: This manual contains important safety and operating instructions for the charger. Read the entire manual before using charger.

User's Guide for HP Series Intelligent Charger

2	SY GEL Battery	⏸️ 🟢 🔴 🔴 🟡 ⏸️
3	LEOCH AGM Battery (Algid43)	⏸️ 🟢 🔴 🔴 🟡 🟡 🟡 🟡 🟡 🟡 🟡 🟡 ⏸️
4	LiFePo4 Battery (Lithium-ICON)	⏸️ 🟢 🔴 🟡 🟡 🟡 🟡 ⏸️

Product Dimensions

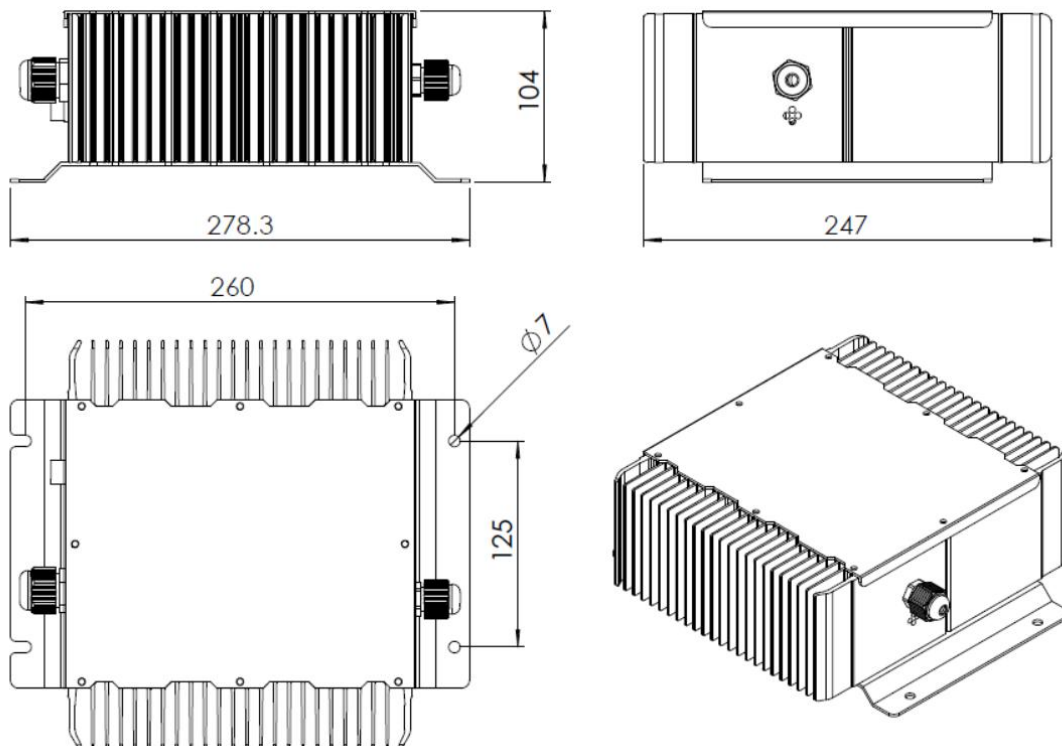

IMPORTANT NOTICE: This manual contains important safety and operating instructions for the charger. Read the entire manual before using charger.